



Description

The SW215 is a very powerful bass cabinet equipped with two 15" loudspeakers. The loudspeakers rear are loaded into a horn, while it's front side are coupled direct radiating. The result is a deep and fast bass response, with a very high sensitivity. It can be either used for long as well as for short throw applications. The cabinet is made of birch plywood and painted in texture black finish.

Applications

The SW215 can be used as a bass cabinet nearly in all applications, such as live or disco in mid or large venues.

FRONT

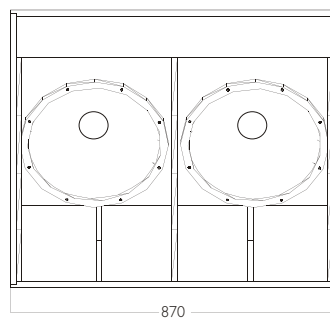

RIGHT

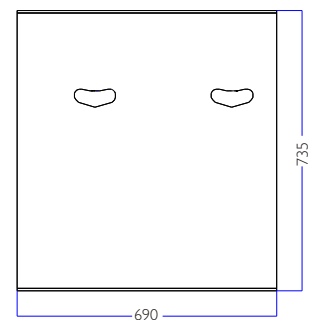

BACK

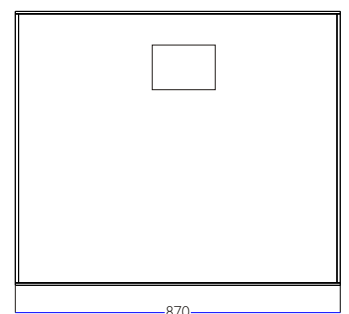

Active PC
version
available

TECHNICAL SPECIFICATIONS

Frequency Response (Hz)	40 Hz-1.2KHz \pm 4dB
Power Handling (Watts)	1200 W RMS
Sensitivity	105 dB (1w/1m)
Nominal peak	135 dB
Coverage angle	N/A
Crossover	up to 1.2 KHz
Impedance	4 Ohm
Drivers	2X15"
Connectors	2x4pin speakon
Dimensions	73x87x69 cm(H x W x D)
Weight	90 Kg

DIAGRAMS

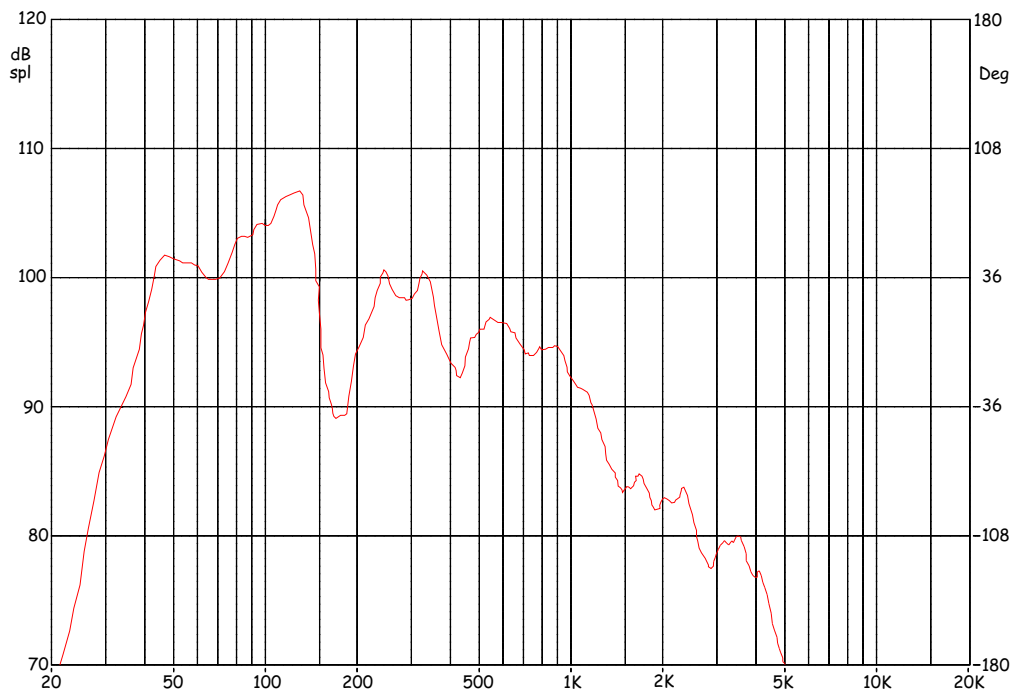

FREQUENCY RESPONSE CURVE



tecnaRE
SOUND SYSTEMS
 Is a™ Designed and
 manufactured in Spain by



Pº Ind. Monte Boyal. C/Encinar 282
 45950 Casarrubios del Monte (Toledo). SPAIN.
 Phone: +34 918 170 110
 Fax: +34 918 183 053
www.tecnare.com
exel@tecnare.com